

# Time Dynamics and the Introduction of New Technologies within IO Analysis

Christa D. Jensen\*

*Regional Research Institute, Morgantown, WV*

Randall W. Jackson †

*Regional Research Institute, Morgantown, WV*

## ***RESEARCH PAPER 2010-3***

***Abstract.*** Although Input Output (IO) models are widely accepted tools for regional scientists and economists alike, there are still many issues to confront during their application, including estimating impacts relative to future years, dynamic impacts, and the introduction of new technologies within economic systems. Oftentimes, especially within energy and environmental subject areas, applications call for not only the introduction of new technologies but also for forecasts of economic impacts that may take years, or even decades, to fully implement. Despite the static nature of the IO modeling framework, these types of situations can be handled successfully and in ways fully consistent with the principles underlying the framework. This paper describes such a methodology, developed in the context of an input-output application for the estimation of impacts associated with the introduction of new energy technologies over a twenty year time horizon, modeling new and existing fossil-fuel technology scenarios from inception through the year 2030. As a demonstration of the method, application results are presented and briefly discussed.

*Key words:* Input-Output, Forecasts, Energy, Impacts assessment

*JEL Category:* C67, R15, Q43

---

\*Christa D. Jensen, Graduate Research Fellow, Regional Research Institute, Department of Economics, West Virginia University, PO Box 6825, Morgantown, WV 26506. Phone: (304) 293-8545; Fax: (304) 293-6699; [Christa.Jensen@mail.wvu.edu](mailto:Christa.Jensen@mail.wvu.edu)

†Randall W. Jackson, Director, Regional Research Institute, PO Box 6825, Morgantown, WV 26506. Phone: (304) 293-8734; Fax: (304) 293-6699; [Randall.Jackson@mail.wvu.edu](mailto:Randall.Jackson@mail.wvu.edu)

## I. Introduction

Although Input Output (IO) models are widely accepted tools for regional scientists and economists alike, there are still many issues to confront during their application, including estimating impacts relative to future years, dynamic impacts, and the introduction of new technologies within economic systems.

Oftentimes, especially within energy and environmental subject areas, applications call for not only the introduction of new technologies but also for forecasts of economic impacts that may take years, or even decades, to fully implement. Although the IO model is a static framework, these types of situations can be handled successfully and in ways fully consistent with the principles underlying the framework.

The most straightforward and conventional IO applications are driven based on a static representation of existing economic structure by a specified total final demand or final demand change vector. Our approach involves the explicit and direct modification of the accounts that characterize the input-output structure of the economic system. The approach we describe in this paper bears a conceptual relationship to a line of structural decomposition analyses typified by (Chenery, Shishido, and Watanabe 1962) or later, Feldman, McClain and Palmer (1987), who decompose temporal change in total output into four effects, namely deviations in domestic demand, imports, exports, and technological change. Whereas they begin with output change and identify the contribution of import substitution, we explicitly modify the structural representation of the economic system in a way that explicitly captures changes in outputs and the import composition of inputs, with the goal of identifying changes in output and other variables of interest derived from output impact estimates. We also use forecasts of other key variables, such as employment compensation, to reflect anticipated structural changes over time. By doing so, magnitudes of impacts are appropriately benchmarked to future levels of economic activity.

This paper describes the methodology developed in the context of the application of input-output methods for the estimation of impacts associated with the introduction of new energy technologies over a twenty year time horizon,<sup>1</sup> modeling new and existing fossil-fuel technology scenarios from inception through the year 2030. Section II describes the methodology used to incorporate new technologies and the changes in the product mix of subsectors below the initial level of industrial aggregation within the initial IO accounts. Section III follows with the description of time dynamics including the manner in which we incorporate forecasted economic data and IO structure for future years, and the mechanism used in phasing in impacts. Section IV describes the implementation of these techniques with respect to the

---

<sup>1</sup> The work was motivated by *NETL/RDS Subtask 404.03.03: Economic Impact of Domestic Fossil-based Resources*.

fossil-fuels application. Section V presents results from a full-scale model analysis using comprehensive data on fossil-fuels and production technologies, and Section VI concludes.

## **II. Introducing New Technologies**

New technologies can be introduced within the commodity by industry IO framework in three distinct ways:

- 1) Splitting an existing aggregated industry sector into parts (disaggregating an existing industry to provide detail on a subsector)
- 2) Defining a new industry that produces a new commodity
- 3) Defining a new industry that produces only existing commodities

In this paper, we focus on 1) and 3) as they are more frequently encountered and therefore arguably of more interest methodologically. In the case of 2), the task involves two distinct activities, the second of which is straightforward and requires little more than adding an industry row and column and commodity column and row to the Make and Use tables. Before this can be done, however, the less well-defined task would be identifying how the commodity would be used by each industry, and for which other commodities, if any, the new commodity would be a substitute. In other words, the (linear) production functions of all industries that use the new commodity would need to be re-specified, which potentially could entail a complete overhaul of the Use matrix. The description of a comprehensive and consistent approach to this more idiographic problem context also would be of value but will await future research.

### ***1) Splitting an aggregate industry into two industry sectors***

Nearly all industry sectors defined within any IO framework represent an aggregation of related individual subsectors, each with its own distinct technologies and corresponding production functions. This characteristic is well known and its implications have often been treated under the *product mix* and *aggregation bias* headings (Miller and Blair 1985; Morimoto 1970; Stevens and Lahr 1993; Lahr and Stevens 2002). When an application calls for changes to or impacts on a specific subsector that is known to be markedly different from its parent sector and for which reliable technology data are available, the analytical model used will be more accurate and informative if this subsector industry is explicitly represented as a new and separate industry. For example, an energy application may call for the examination of impacts on *Oil Extraction* and *Natural Gas Extraction* for a region of, or the entire, U.S. and the emphasis of the application might be focused primarily on impacts on the natural gas industry. Published U.S. IO data are only available for an aggregated sector labeled *Oil and Gas Extraction*. In the

event that equivalent input-output data on one or the other subsectors are available, it is possible to split the existing aggregate industry to reflect the two respective industry technologies – and commodity outputs – separately.

The procedure below describes splitting an existing industry into exactly two subsectors. Note that in this instance, it is assumed that no new commodity is being produced. The procedure is relatively simple and represents little that is new from a conceptual standpoint, but is described both to begin introducing necessary notation and to provide a comprehensive explication of the modeling framework underlying the application reported in Section V. Note also that the procedure can be generalized to incorporate any number of subsectors – splitting into additional sectors merely replicates the two-subsector procedure, splitting one or both of the new subsectors again as many times as desired, subject to the available data and application objectives.

When splitting an existing industry and its technology representation in two, the procedure requires incorporating new data corresponding to the subsector for which adequate data are available, and an adjusted aggregate sector corresponding to the remainder of the initial aggregate sector once the new sector data have been extracted. The necessary data include a new Use column (intermediate use expressed in dollar terms, with a known dollar output total,  $U^{new}$ , value-added entries corresponding to employment compensation, gross operating surplus, and taxes all expressed in dollar terms,  $EC^{new}$ ,  $GOS^{new}$ ,  $T^{new}$  and a Make row for the new industry,  $V^{new}$ . The new Make row and Use column are then subtracted from their initial aggregate counterparts, and the new value-added components are subtracted from the aggregate.

$$U_i^{adjusted} = U_i^{aggregate} - U_i^{new}$$

$$EC^{adjusted} = EC^{aggregate} - EC^{new}$$

$$GOS^{adjusted} = GOS^{aggregate} - GOS^{new}$$

$$T^{adjusted} = T^{aggregate} - T^{new}$$

$$V_j^{adjusted} = V_j^{aggregate} - V_j^{new}$$

The new row and column form one subsector and the adjusted row and column replace the initial aggregate sector data to define adjusted Make and Use tables. The procedure results in rectangular Make and Use tables with more industries than commodities, which can be problematic for some formulations

of the commodity industry framework solutions<sup>2</sup>. Since our formulation uses the industry-technology assumption and an industry by industry inverse, rectangular matrices do not present further conceptual challenges and therefore the conventional model treatment can be followed.

### **3) *Defining a new industry that produces only existing commodities***

As technological development naturally proceeds, and as industries struggle to cope with changing attitudes towards energy-efficiency and the environment, new industries and/or technologies will undoubtedly emerge. Many of these new technologies are expected to be employed to produce only existing commodities. Indeed, current environmental concerns coupled with higher energy prices are leading to the development and implementation of new energy producing technologies such as coal to liquids, which in part motivated the current research application.

Defining a new industry that produces only existing commodities is also relatively straightforward, requiring the specification of a new Use table column and value added components, and a corresponding Make table row. Once these are specified, they simply augment the initial accounts. Once again, the results are rectangular Use and Make tables. The output solution formulation used in the application here will be presented in detail in Section IV.

## **III. Time Dynamics**

There are numerous challenges facing input-output analysts charged with estimating impacts of the introduction of new technologies or changes in production levels of existing sectors in future years. First, input-output impact estimates carry no explicit temporal information. The total impact of a final demand change, for example, might require less than a year, one year, or more than one year to be fully realized. While there have been attempts to address the time issue in IO modeling (Romanoff and Levine 1981, 1986; Jackson 1989), most analysts commonly assume a one year impact horizon, based loosely on the one year time frame represented in the accounts. This assumption is probably most reasonable for incremental rather than very large impacts. In the application described here, the one-year impact horizon assumption is used.

The second challenge concerns the separation of impacts that can be expected to recur on a regular basis from those that are short-lived. Many studies involve the estimation of impacts of new production

---

<sup>2</sup> Problems only arise under the commodity technology assumption when trying to arrive at a unique total requirements matrix. See Web Appendix 5W.1 for Miller and Blair (2009).

facilities and their accompanying output. In these cases, there are generally impacts associated with production on a continuing basis, which can be expected to continue to be realized in future years, and impacts associated with facility construction which can normally be expected to run their course in a shorter time span related to the construction period. Additionally, construction might well extend over several years, and production might be phased in, including a period prior to final facility completion and ramping up to stable output levels over subsequent years. Hence, a realistic representation of impacts might well describe one-time impacts over a sequence of years, along with production impacts that are phased in over the same or a more extended period. The method described in this paper provides mechanisms to account for both situations.

Third, when impacts are estimated for future years, the changes in output levels will be relative to economies whose industrial output distributions are also changing. For years in the near future, the inaccuracies introduced by ignoring this reality might well be acceptably small. As the time horizon increases, however, changes in economic production levels can result in substantial inaccuracies in impacts assessments. As an example, consider an economy that currently requires the import of 75% of its widgets. A new facility whose widget production could replace imports altogether were it in full production today, might well only partially replace import demand in a future year when the economy-wide demand for widgets has also grown. Hence, changes in production levels will have time-varying economic impacts related to future industrial and final demand levels. Similarly, productivity changes will alter the scale of employment impacts normally derived from output impacts. Hence, the method described below provides mechanisms to deal with an economy whose future activity levels and industry-level productivities are expected to change, provided that forecasts exist for these activity levels. The approach involves adjustments to output and other key variables consistent with the forecast, so that the impacts of interest will be assessed within the context of other anticipated changes in economic structure.

Forecasting is the first step in the modeling process. For the application in this paper, forecast data from the NEMS model (EIA 2009) are used to recalibrate the 2007 base economic data to be consistent with changes in the scale and composition of industry activity for future impact years selected by the user. This re-scaling procedure enables an analysis of fossil-fuel related impacts that occur in future years. The model employed rests on the assumption that the intermediate inter-industry structure corresponding to production functions and industry-commodity output relationships remain constant throughout the forecast period. This implies that intermediate input substitution due to temporal changes in price and temporal changes in productivity are not captured explicitly.

### **Forecast Methodology**

The first step in this process is to update the values of industry production (Make) and consumption (Use) so that they are consistent with known forecasts of industry output levels. This requires industry-specific dollar values in the Make,  $V$ , and Use,  $U$ , tables to be adjusted by the ratio of forecast industry output,  $g_f$ , to initial industry output,  $g_o$ . Relative commodity price relationships are embedded in these adjustments of industry transactions.

$$U_f = U \hat{g}_f \hat{g}_0^{-1}$$

$$V_f = \hat{g}_f \hat{g}_0^{-1} V$$

Next, the known forecast values of industry employment,  $employment_t$ , other value added (including employee compensation,  $EC_f$ , gross operating surplus,  $GOS_f$ , and taxes on production and imports, less subsidies,  $T_f$ ), household consumption,  $HHC_f$ , commodity imports,  $M_f$ , and commodity exports,  $X_f$ , all override their initial counterparts.

Updating the value added entries according to their forecasts may result in small differences between industry output values calculated as column sums of the Use table and the forecast industry output values. The following step is taken to reconcile the new industry output levels with the resulting forecast estimates. First, the forecast values of industry output are reinstated by adjusting the value of gross operating surplus accordingly.

$$V_f i - i U_f^t = \Delta GOS$$

where,

$$U_f^t = \begin{bmatrix} \frac{U_f}{-} \\ \frac{EC_f}{-} \\ \frac{GOS_f}{-} \\ \frac{T_f}{-} \end{bmatrix}$$

$$GOS_f \Leftarrow GOS_f + \Delta GOS$$

subject to,

$$GOS_f > 0$$

The implication of this adjustment is that while the relative inter-industry structure remains constant, there can be substitution between intermediate inputs and value added. Industry productivity changes indicated by the forecast data are incorporated simply by using the forecast productivity values in place of those for 2007.

### **Phase-in Methodology**

The implementation of many new technologies and new production schedules will occur over a sequence of years. Construction may be expected to extend over several years, and production could possibly be phased in, including a period prior to final facility completion and ramping up to stable output levels over subsequent years. The method described below provides a mechanism to account for phase in periods and their implementation within the IO framework.

A standardized phase in vector,  $\lambda$ , of dimension  $(m \times 1)$  where  $m$  is the number of years in the study, is defined by the user and used to phase in impacts of any length. For simplicity, a total impact for each industry is first defined and then split out using the respective phase in vector. A separate and distinct phase in vector can be defined for each total impact to account for different production or construction schedules.

$$\text{IMPACT}^{\text{phase-in}} = \text{IMPACT}^{\text{total}}_i * \lambda_i$$

Each element of  $\text{IMPACT}^{\text{phase-in}}$  then corresponds to an industry impact for a specific year of analysis. These industry impacts are compiled into a vector of output impacts to be input into each annual IO framework. While this is not a perfect and complete solution to the time-phasing problem of classical impact assessments, it takes the analysis one step closer to reality by spreading the direct impacts out over corresponding phasing in periods.

## **IV. Fossil-Fuels Application**

Three critical elements in addressing energy concerns are energy supply, environmental impacts, and economic impacts. DOE/NETL has recently published several reports addressing the potential of state-of-the-art and next generation technologies to enhance domestic energy supplies and has conducted analyses on both the environmental impacts of technologies and impact mitigation pathways<sup>3</sup>. This application aims to complement these reports and analyses by addressing the potential economic and, in

---

<sup>3</sup> *Coal & Power Reference Shelf* (<http://www.netl.doe.gov/technologies/coalpower/refshelf.html>);  
*Carbon Sequestration – Resources Analysis Reference Shelf*.  
([http://www.netl.doe.gov/technologies/carbon\\_seq/Resources/Analysis/](http://www.netl.doe.gov/technologies/carbon_seq/Resources/Analysis/));  
*Energy Analyses Benefit Analysis* (<http://www.netl.doe.gov/energy-analyses/benefit.html>).



particular, employment, impacts that could be associated with increasing the domestic energy supply through increased onshore and/or offshore oil and natural gas production and with the implementation of Coal-to Liquids (CTL) technology within the United States.

The model estimates fossil-fuel related impacts of future production changes. Analytical results are generated for the years 2010 through 2030. The model uses forecast data to recalibrate the 2007 base economic data to be consistent with changes in the scale and composition of industry activity in the future. Forecast functionality allows users to specify phase-in schedules for oil, natural gas, or CTL production increases, along with annual construction schedules.

### **Application Forecast**

As mentioned before, this application involves the estimation of impacts from inception through 2030. As the first possible year for changes is 2010, there are 21 years of forecasts involved using 2007 base data. Forecasts of data for all 21 years are made and then used to calculate impacts based on user-entries.

Make and Use entries are updated for each year relative to the base year, 2007, using known forecasts of industry output levels for each year. Forecasts of growth rates were obtained from the DOE's NEMS modeling system.

$$U_t = U \hat{g}_t \hat{g}_{2007}^{-1}$$

$$V_t = \hat{g}_t \hat{g}_{2007}^{-1} V$$

Next, the forecast values of industry employment,  $employment_t$ , other value added (including employee compensation,  $EC_t$ , gross operating surplus,  $GOS_t$ , and taxes on production and imports, less subsidies,  $T_t$ ), household consumption,  $HHC_t$ , commodity imports,  $M_t$ , and commodity exports,  $X_t$ , all override their initial counterparts.

As anticipated, updating the value added entries does result in small differences between industry output values calculated as column sums of the Use table and the forecast industry output values. This difference is reconciled through the adjustment to gross operating surplus described in Section III.

$$V_t i - i U_t^t = \Delta GOS$$

where,

$$U_t^t = \begin{bmatrix} \frac{U_t}{EC_t} \\ \frac{GOS_t}{T_t} \end{bmatrix}$$

$$GOS_t \Leftarrow GOS_t + \Delta GOS$$

subject to,

$$GOS_t > 0$$

In running the model, negative values for gross operating surplus resulted for some industries after this adjustment. Because most industries normally operate with positive gross operating surplus, the following step is also included to ensure that gross operating surplus does not fall below ten percent of its original 2007 value after the previous adjustment.<sup>4</sup> In the event that it does, total output in the forecast year for that industry is increased by the amount necessary to return gross operating surplus to ten percent of its original 2007 value.

$$\Delta GOS_{-2,t,i} = .1\sigma_{GOS_{2007,i}} - GOS_{t,i}$$

$$V_{i,i} \Leftarrow V_{i,i} + \Delta GOS_{-2,t,j}$$

### **Splitting/Adding Industries**

Within the fossil-fuels application, it was necessary to not only split *Oil and Gas Extraction* into its onshore and offshore components, but also introduce a new coal-to-liquids (CTL) technology within the initial IO framework. The CTL industry is expected to only produce existing commodities such as those that result from *Petroleum Refineries*.

Published IO data for the US reports a single industry, *Oil and Gas Extraction*, which encompasses not only oil and natural gas components but also onshore and offshore components. In order to more accurately identify impacts for onshore and offshore extraction separately, it was important to this application to split this industry accordingly. Data limitations and user-entry conflicts necessitated the

---

<sup>4</sup> Negative GOS was experienced in multiple years in industries such as *Warehousing and Storage* and *Government*. The ten percent value was chosen after some consideration of the time period, forecast output changes, and industries in question. This value can, and probably should, change depending on the application specifications.

aggregation of the fossil fuels industries (*Onshore Oil and Gas Extraction, Offshore Oil and Gas Extraction, Coal-to-Liquids*) throughout the matrix manipulation steps. Afterwards, these industries are disaggregated when results are reported.

First, we manipulate the data in the Use table to reflect these changes to the economic system. The existing data for sector 3, *Oil and Gas Extraction*, is split using the Use data for *Offshore Oil and Gas Extraction* and the method described in Section II. Also, the production technology of the *Coal-to-Liquids* industry and value added entries for these industries are inserted. We can now define three corresponding Use table columns and their respective total industry output values.

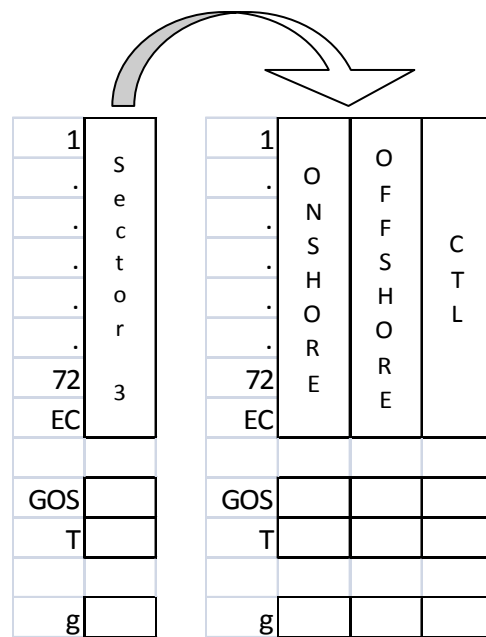

These columns are then standardized by total industry output to define the standardized base technology for each industry.

|    |                                 |                                      |             |
|----|---------------------------------|--------------------------------------|-------------|
| 1  | O<br>N<br>S<br>H<br>O<br>R<br>E | O<br>F<br>F<br>S<br>H<br>O<br>R<br>E | C<br>T<br>L |
| .  |                                 |                                      |             |
| .  |                                 |                                      |             |
| .  |                                 |                                      |             |
| .  |                                 |                                      |             |
| .  |                                 |                                      |             |
| 72 |                                 |                                      |             |
| EC |                                 |                                      |             |

Production levels for the base year and for the impact scenario for each of these industries are then used to generate weighted-average columns for the respective analysis year. This happens in the following manner:

For the base year:<sup>5</sup>

- The Onshore column is multiplied by total industry output for *Onshore Oil and Gas Extraction*.
- The Offshore column is multiplied by total industry output for *Offshore Oil and Gas Extraction*.
- The CTL column is always multiplied by 0 since there is no CTL production in the base year.

|    | BASE                            |                                 |             |
|----|---------------------------------|---------------------------------|-------------|
| 1  | O<br>N<br>S<br>H<br>O<br>R<br>E | O<br>F<br>S<br>H<br>O<br>R<br>E | C<br>T<br>L |
| .  |                                 |                                 |             |
| .  |                                 |                                 |             |
| .  |                                 |                                 |             |
| .  |                                 |                                 |             |
| .  |                                 |                                 |             |
| 72 |                                 |                                 |             |
| EC |                                 |                                 |             |

These three columns are then aggregated into one column by summing across the rows. This aggregate industry replaces *Oil and Gas Extraction* in the Base Use matrix,  $U_{2007}$ , and is used for all subsequent operations that involve Initial Use for the base year.

---

<sup>5</sup> These data manipulations for the base year should have no impact on the base year use column, but are described here because they form the foundation for forecast year calculations, and because this process would need to be replicated if a new base year is eventually incorporated.

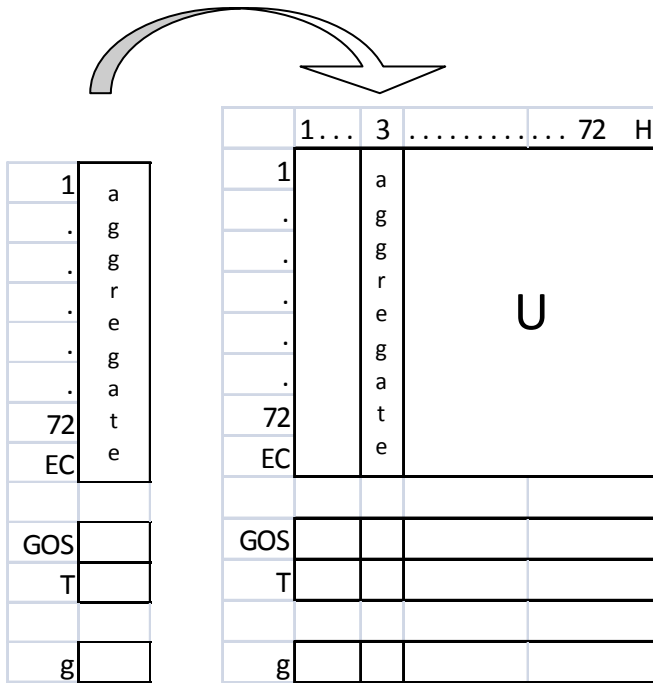

For each year of the Impact Scenario:

- The Onshore column is multiplied by total industry output for *Onshore Oil and Gas Extraction* plus the value of additional onshore production for the current impact year found in phase in calculations.
- The Offshore column is multiplied by total industry output for *Offshore Oil and Gas Extraction* plus the value of additional offshore production for the current impact year found in phase in calculations.
- The CTL column is multiplied by the value of CTL production in the current impact year.

|    | IMPACT                          |                                      |             |
|----|---------------------------------|--------------------------------------|-------------|
| 1  | O<br>N<br>S<br>H<br>O<br>R<br>E | O<br>F<br>F<br>S<br>H<br>O<br>R<br>E | C<br>T<br>L |
| .  |                                 |                                      |             |
| .  |                                 |                                      |             |
| .  |                                 |                                      |             |
| .  |                                 |                                      |             |
| .  |                                 |                                      |             |
| .  |                                 |                                      |             |
| 72 |                                 |                                      |             |
| EC |                                 |                                      |             |

- Impact Use,  $\tilde{U}$ , is defined as:

$$\tilde{U} = U \text{ modified for impacts, where impacts are defined as follows:}$$

Recall that Sector 3 is Oil and Gas Extraction Commodity

$$\tilde{u}_3 = (u_3)\zeta$$

where,  $\zeta$  is an oil and gas price ratio<sup>6</sup>.

- $\zeta$  is also used to adjust the values for onshore and offshore production of the *Oil and Gas Extraction* commodity at the disaggregated level.
- The three columns are then aggregated into one column by summing across the rows. This aggregate industry replaces sector 3, *Oil and Gas Extraction* in the Impact Use matrix which is used in all subsequent operations involving Impact Use.

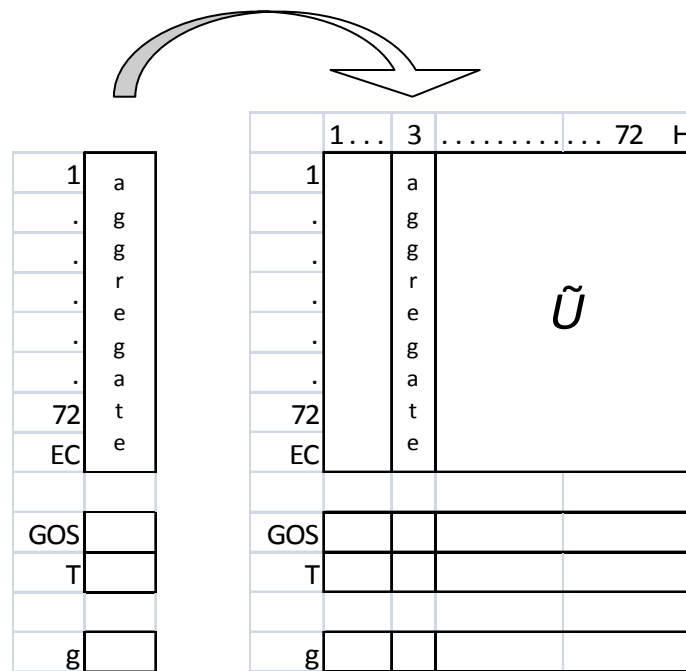

We then make similar adjustments to the Make table. The existing Make data for sector 3, *Oil and Gas Extraction* is split into *Onshore Oil and Gas Extraction* and *Offshore Oil and Gas Extraction* according to Section II. The production technology of the *CTL* industry is also inserted.

<sup>6</sup> See Appendix A for description and calculations involved with the oil and gas price ratio.



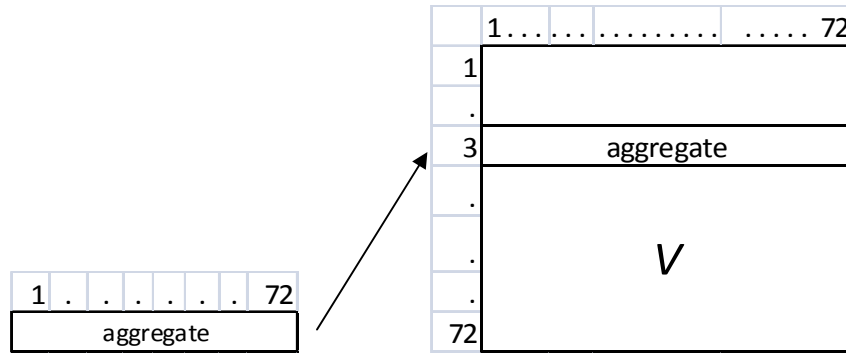

For each year of the Impact Scenario:

- The Onshore row is multiplied by total industry output for *Onshore Oil and Gas Extraction* plus the value of additional onshore production for the current impact year.
- The Offshore row is multiplied by total industry output for *Offshore Oil and Gas Extraction* plus the value of additional offshore production for the current impact year.
- The CTL row is multiplied by the value of CTL production in the current impact year.

| IMPACT   |   |   |   |   |   |   |    |
|----------|---|---|---|---|---|---|----|
| 1        | . | . | . | . | . | . | 72 |
| ONSHORE  |   |   |   |   |   |   |    |
| OFFSHORE |   |   |   |   |   |   |    |
| CTL      |   |   |   |   |   |   |    |

The three rows are then aggregated into one row by summing each of the columns. This aggregate industry replaces *Oil and Gas Extraction* in the Make matrix, which can now be defined as Impact Make,  $\tilde{V}$ , which is used for all subsequent operations that involve Impact Make. In order to provide an explicit representation of import substitution, the value of commodities corresponding to new production will be assumed to offset foreign imports. This treatment of forecast foreign import values and the subsequent calculations for import substitution make such an application suitable for regional analysis as well as analyses at the regional level.



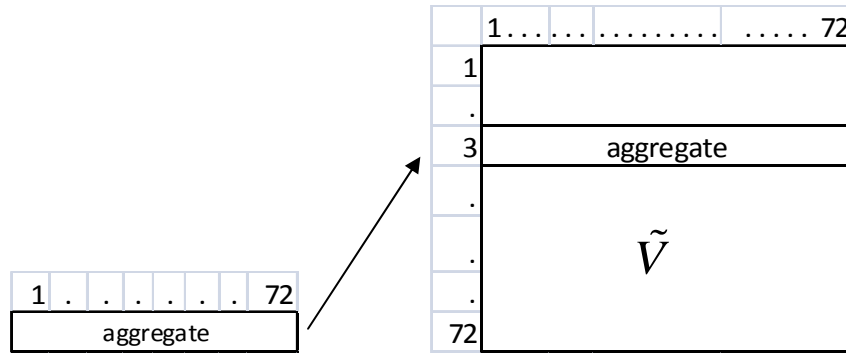

Values are also incorporated for value-added for both the *Offshore Oil and Gas Extraction* and *CTL* industries. These values include: Employee Compensation, Gross Operating Surplus, and Taxes. There is also an estimate of the number of employees associated with each industry. These values are introduced in order to calculate tax impacts, value-added, and employment results.

Output impacts are in turn calculated for the entire model with the aggregated form of sector 3. The aggregate output impact for this sector is then disaggregated into output impacts for *Onshore Oil and Gas Extraction*, *Offshore Oil and Gas Extraction*, and *CTL*. Since the values for new *Offshore Oil and Gas Extraction* and *CTL* output are defined by user-entries, we can assign these values and calculate the new output for *Onshore Oil and Gas Extraction*. In cases for which onshore impacts differ from those specified by a user input, differences reflect the indirect adjustments in intermediate and final demand. This disaggregated vector of new output values is then used to calculate results tables<sup>7</sup>.

Once base data has been forecasted and the economic structure adjusted for split/additional industries, user-entries are phased in as described in Section III and entered as impacts into each individual year's IO specification.

## V. Fossil-Fuels Results

The two illustrative impact scenarios reflect changes to future oil and natural gas production. The first scenario models a 10% increase in onshore oil and natural gas and the second a 10% increase in offshore oil and natural gas. As future technologies and energy measures are not scheduled to come online for a few more years, all construction of new wells and pipelines is assumed to take place in equal shares in 2013 and 2014 and any additional natural gas processing plants are assumed to be constructed in 2013. New production is phased-in beginning in the year 2014 (30% of the increase is online in 2014, 60% of

<sup>7</sup> See Appendix A for the remaining IO calculations involved in generating results tables.

the increase is online in 2015, and 100% of the increase is online in 2016). Since production is scheduled to begin in 2014, total amounts of increased production are calculated as 10% of the estimated production levels for 2013.

Within the fossil-fuels application, users can enter such specifications which constitute a project. Multiple projects can be specified and stored in a project library. Scenarios for model analysis can then be built by grouping one or more projects. The intent is to provide the user with as much flexibility as possible, and to alleviate the burden of re-entering project data for subsequent scenarios. Impacts in any year can be 0. The design and use of projects and scenarios are a major strength of the application and allow for easy implementation of the aforementioned methodologies.

This application primarily captures the effects of increases in production as they relate to import substitution. Based upon forecast data, we know that the economy as a whole tends to change in overall size and structure. In the first few forecast years, the size of the overall economy declines. For this reason, the import substitution impact is quite large in these years. In latter forecast years, the national economy begins to grow year over year, resulting in a decline in the proportions of imports that are being substituted for over time. Also during these latter years, many other inter-industry multipliers also decline due to a greater reliance on imports over the entire inter-industry structure. The result is a system-wide decline in impact multipliers, which explains the decreasing economic impacts over time observed in the results reported below.

Scenario 1

Table 1: New Natural Gas Production for 10% Increase in Onshore Oil and Natural Gas

| New Natural Gas Production  |           |
|---|-----------|
| Increased Marketed Production (MMcf)                                | 1,625,983 |
| Natural Gas not requiring processing (MMcf)                         | 550,605   |
| Processed Natural Gas (MMcf)  | 1,075,378 |
| Extraction Loss (MMcf)  | 76,556    |
| Extracted Liquids (Mbbbl)   | 55,027    |
| Dry Natural Gas (MMcf)  | 998,822   |
| Total Dry Natural Gas to Market (MMcf)                              | 1,549,427 |
| Offset Imports (million \$)   | \$ 10,526 |
| Additional Output from Natural Gas Extraction Industry (million \$) | \$ 15,068 |
| Natural Gas to US Processing and Distribution (million \$)          | \$ 9,968  |
| Increase Exports (million \$)                                       | \$ 0      |
| Natural Gas Plant Liquids (million \$)                              | \$ 5,101  |

Table 2: New Oil Production for 10% Increase in Onshore Oil and Natural Gas

| New Oil Production  |          |
|---|----------|
| Increased Crude Oil Production (Mbbbl)                      | 117,844  |
| Offset Imports (million \$)                                 | \$ 7,937 |
| Additional Output from Oil Extraction Industry (million \$) | \$ 7,741 |
| Crude Oil to US Refineries (million \$)                     | \$ 7,741 |
| Increased Exports (million \$)                              | \$ 0     |

Table 3: New Construction for 10% Increase in Onshore Oil and Natural Gas

| New Oil and Natural Gas Construction                             |             |           |
|--|-------------|-----------|
|  | Natural Gas | Oil       |
| Number of New Wells (wells)                                      | 50,456      | 37,397    |
| New Well Construction Costs (million \$)                         | \$ 68,197   | \$ 47,178 |
| Pipeline Construction Costs (million \$)                         | \$ 94       | \$ 3,171  |
| Number of New Natural Gas Processing Plants (plants)             | 0           |           |
| New Natural Gas Processing Plant Construction Costs (million \$) | \$ 0        |           |

Table 4: Land-Lease Bonuses and Royalties for 10% Increase in Offshore Oil and Natural Gas

| Land-Lease Bonuses and Royalties from Oil and Gas Production (million \$) |          |
|---|----------|
| Land-Lease Bonus from Onshore Oil and Gas                                 | \$ 399   |
| Royalties from Onshore Oil and Gas  | \$ 3,802 |

Figure 1: Total Output and Value Added Impacts from Import Substitution

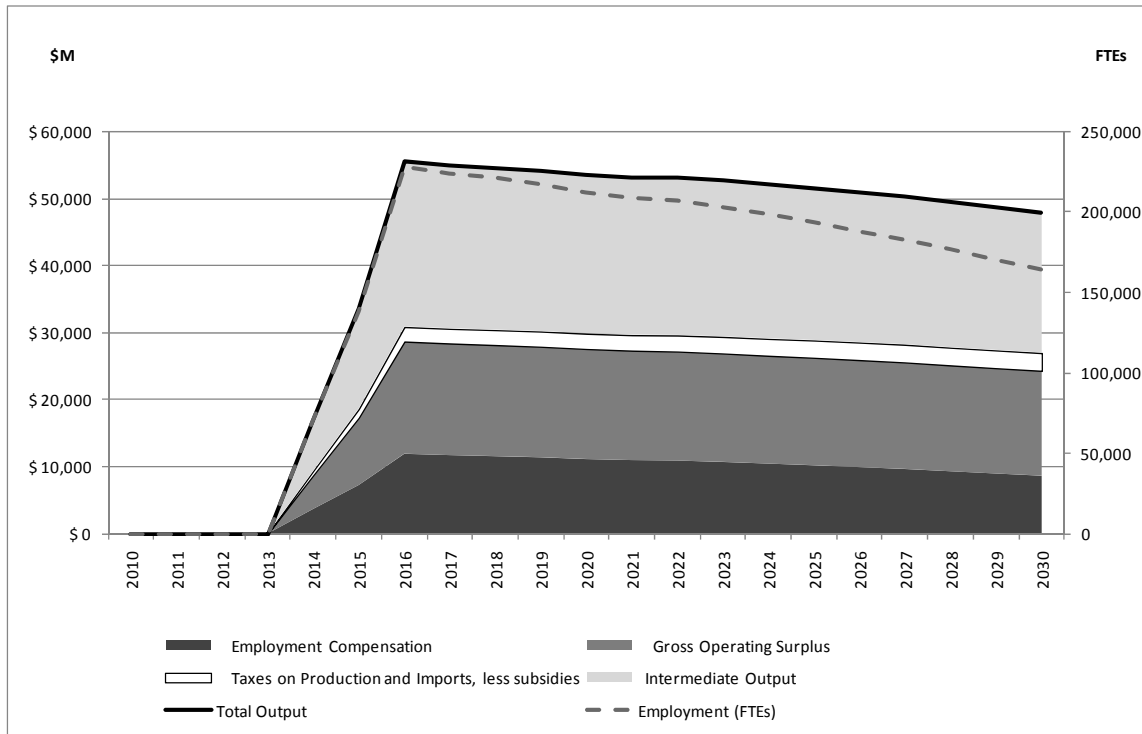

Figure 2: Import Substitution Output Impacts for Aggregate Sectors

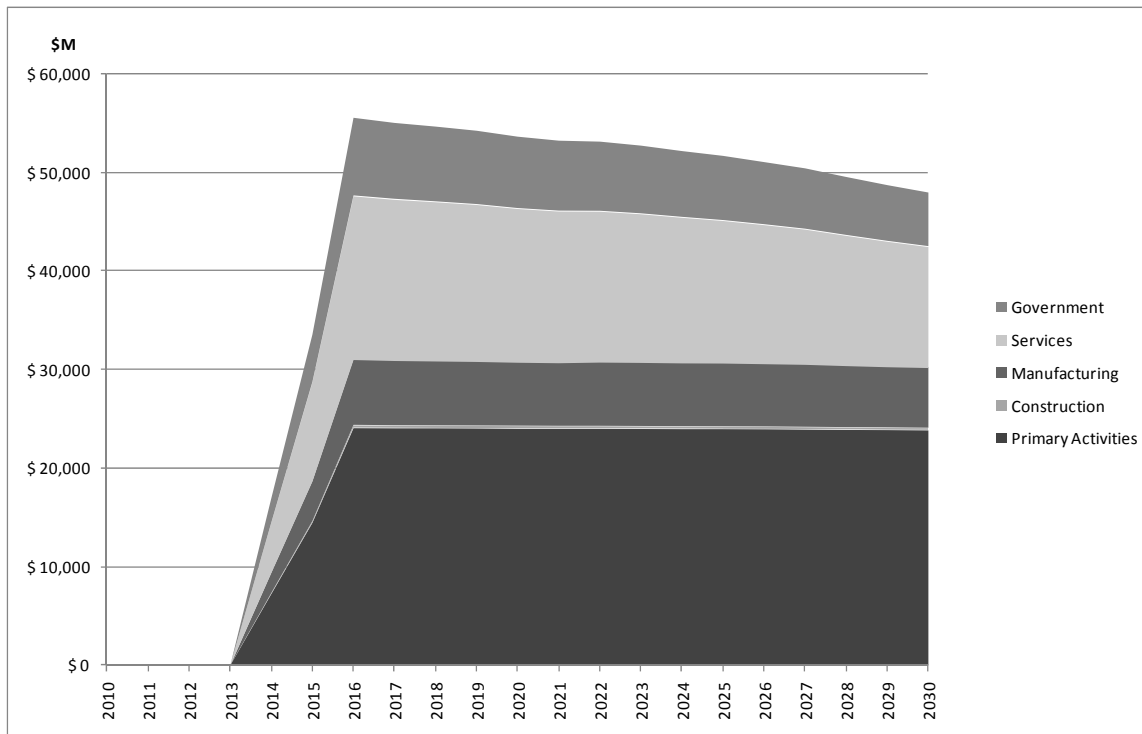

Figure 3: Import Substitution Employment Compensation Impacts for Aggregate Sectors

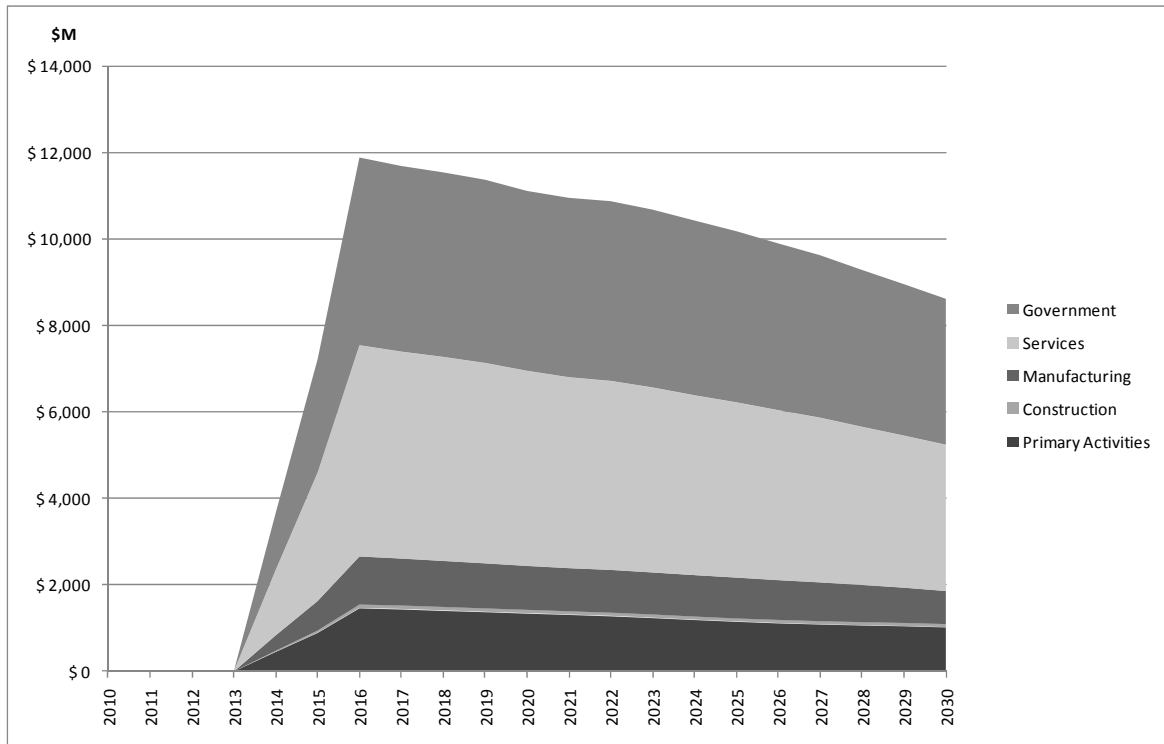

Figure 4: Import Substitution Employment Impacts for Aggregate Sectors

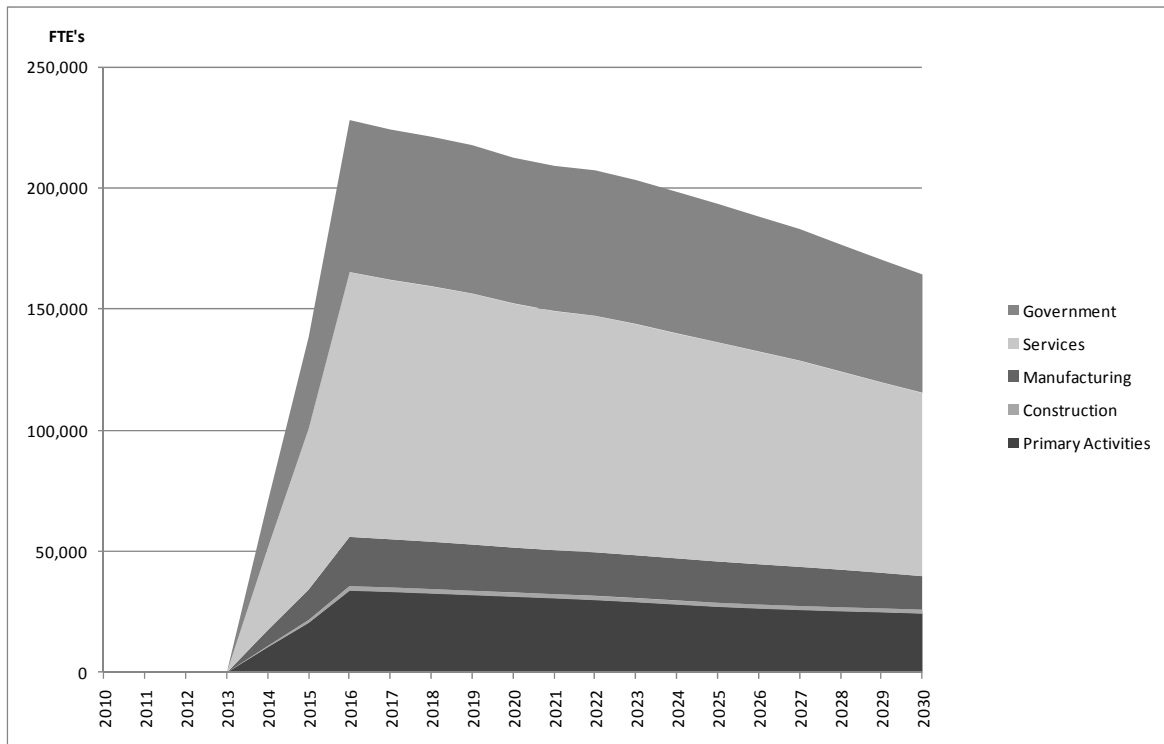

Figure 5: Total Output and Value Added Impacts from Construction

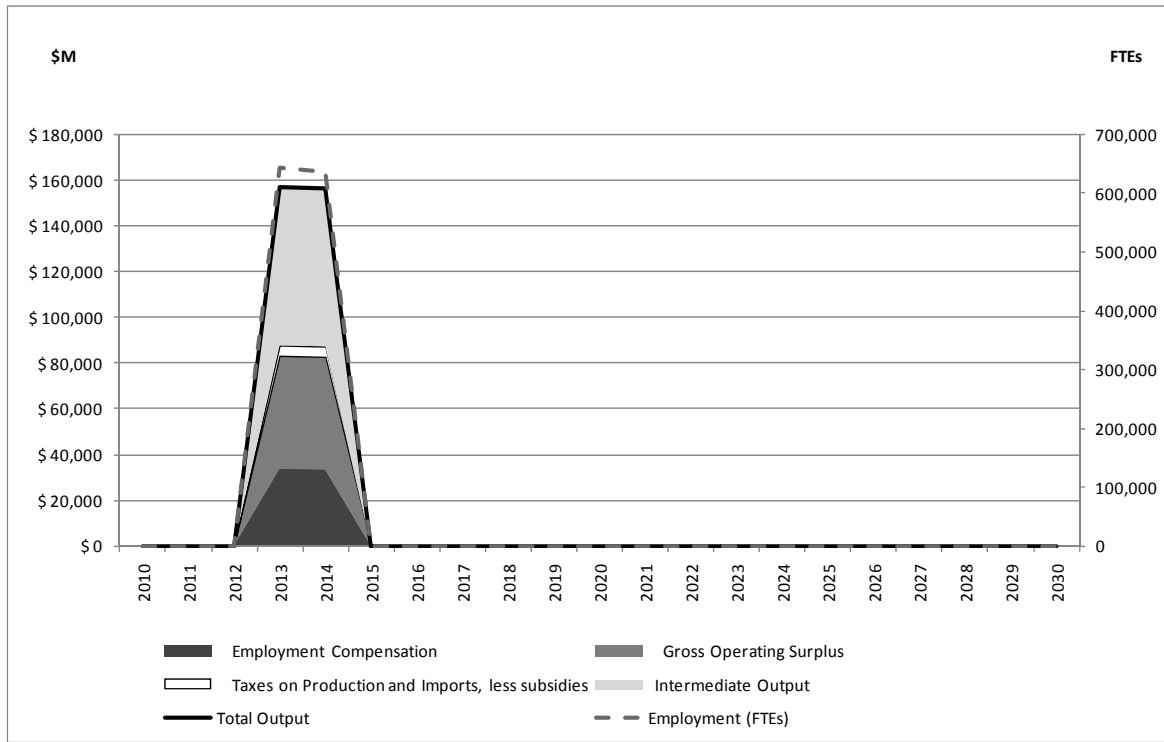

Figure 6: Construction Output Impacts for Aggregate Sectors

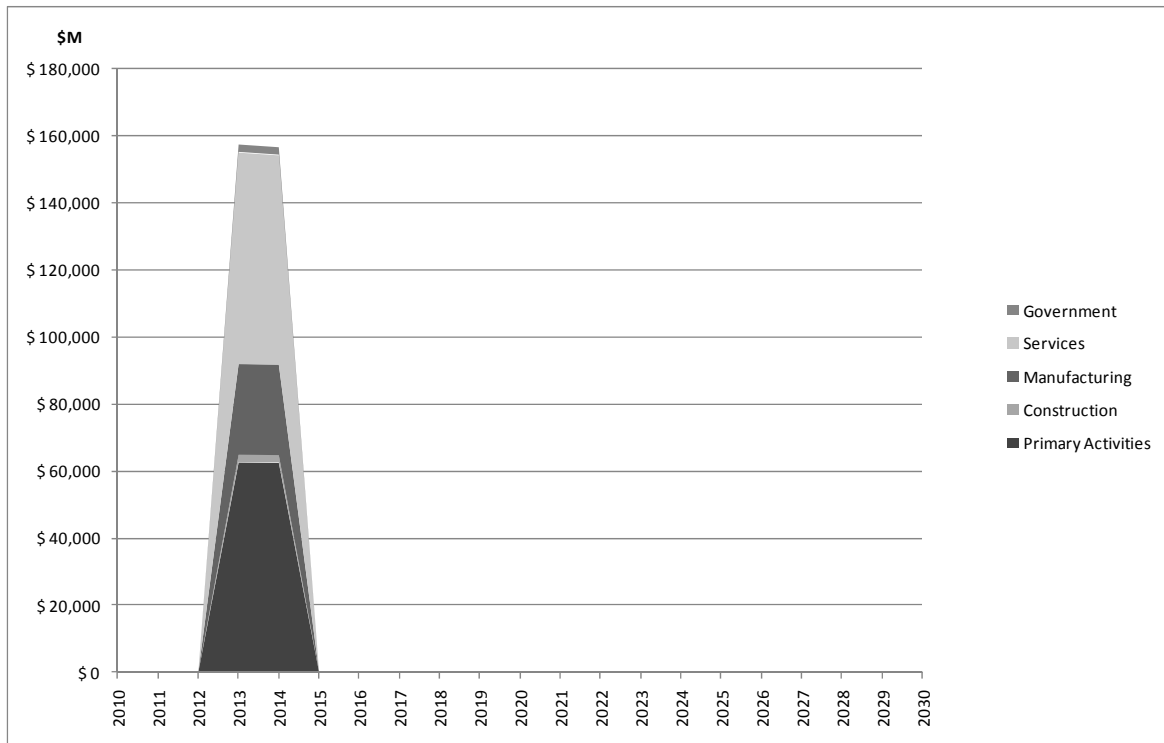

Figure 7: Construction Employment Compensation Impacts for Aggregate Sectors

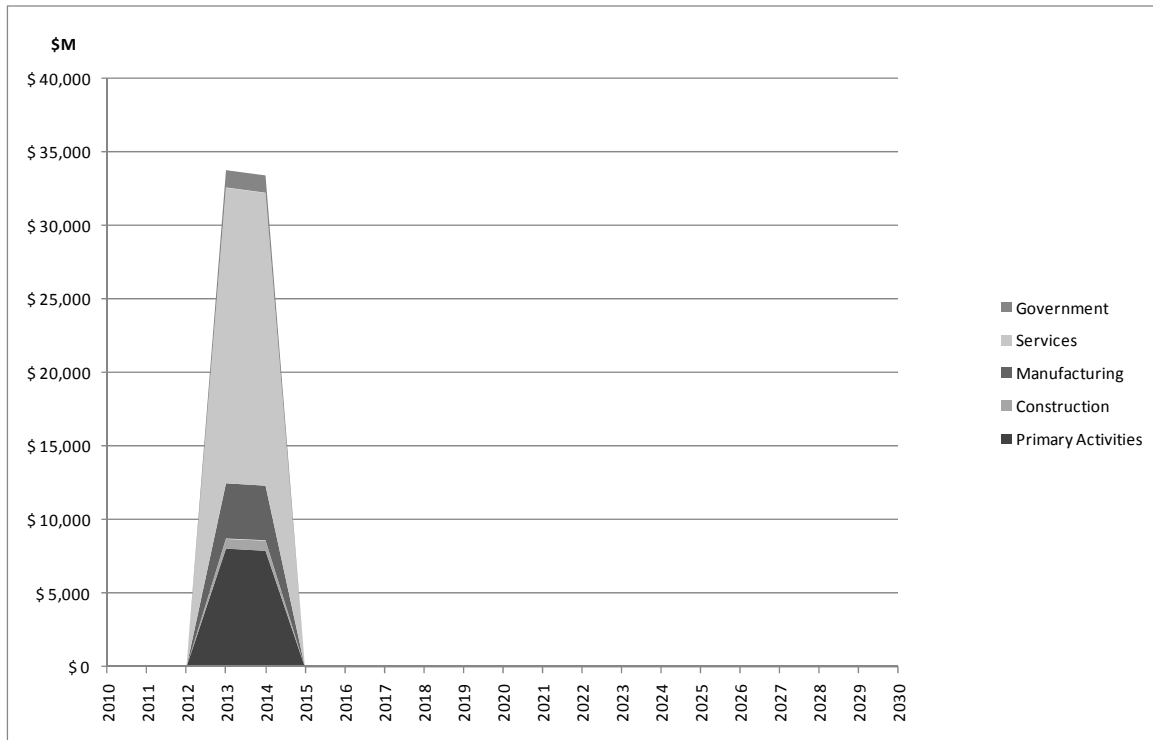
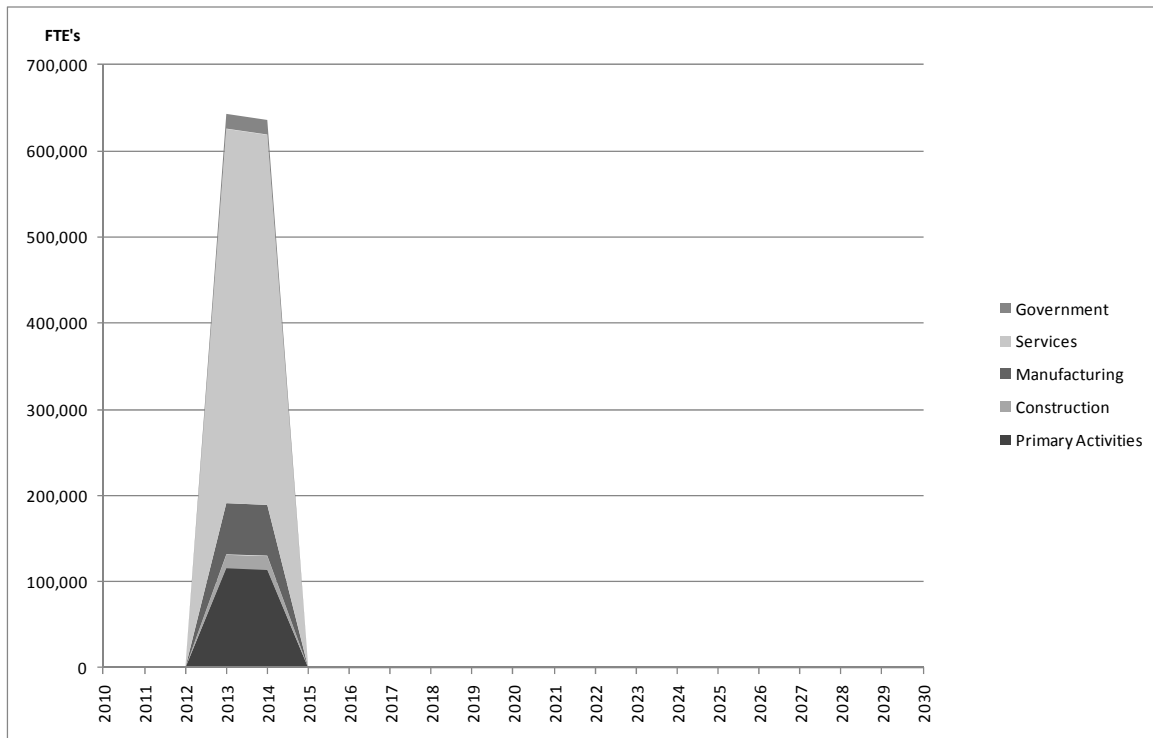

Figure 8: Construction Employment Impacts for Aggregate Sectors



Scenario 2

Table 5: New Natural Gas Production for 10% Increase in Offshore Oil and Natural Gas

| New Natural Gas Production  |          |
|---|----------|
| Increased Marketed Production (MMcf)                                | 265,706  |
| Natural Gas not requiring processing (MMcf)                         | 89,976   |
| Processed Natural Gas (MMcf)  | 175,730  |
| Extraction Loss (MMcf)  | 12,510   |
| Extracted Liquids (Mbbbl)   | 8,992    |
| Dry Natural Gas (MMcf)  | 163,220  |
| Total Dry Natural Gas to Market (MMcf)                              | 253,196  |
| Offset Imports (million \$)   | \$ 1,720 |
| Additional Output from Natural Gas Extraction Industry (million \$) | \$ 2,462 |
| Natural Gas to US Processing and Distribution (million \$)          | \$ 1,629 |
| Increase Exports (million \$)                                       | \$ 0     |
| Natural Gas Plant Liquids (million \$)                              | \$ 833   |

Table 6: New Oil Production for 10% Increase in Offshore Oil and Natural Gas

| New Oil Production  |          |
|---|----------|
| Increased Crude Oil Production (Mbbbl)                      | 57,170   |
| Offset Imports (million \$)                                 | \$ 3,850 |
| Additional Output from Oil Extraction Industry (million \$) | \$ 3,755 |
| Crude Oil to US Refineries (million \$)                     | \$ 3,755 |
| Increased Exports (million \$)                              | \$ 0     |

Table 7: New Construction for 10% Increase in Offshore Oil and Natural Gas

| New Oil and Natural Gas Construction                             |             |            |
|--|-------------|------------|
|  | Natural Gas | Oil        |
|  | Offshore    | Offshore   |
| Number of New Wells (wells)                                      | 307         | 8,167      |
| New Well Construction Costs (million \$)                         | \$ 21,521   | \$ 572,507 |
| Pipeline Construction Costs (million \$)                         | \$ 1,382    | \$ 36,752  |
| Number of New Natural Gas Processing Plants (plants)             |             |            |
| New Natural Gas Processing Plant Construction Costs (million \$) |             |            |



Table 8: Land-Lease Bonuses and Royalties for 10% Increase in Offshore Oil and Natural Gas

| Land-Lease Bonuses and Royalties from Oil and Gas Production (million \$) |          |
|---|----------|
| Land-Lease Bonus from Offshore Oil and Gas                                | \$ 137   |
| Royalties from Offshore Oil and Gas                                       | \$ 1,166 |

Figure 9: Total Output and Value Added Impacts from Import Substitution

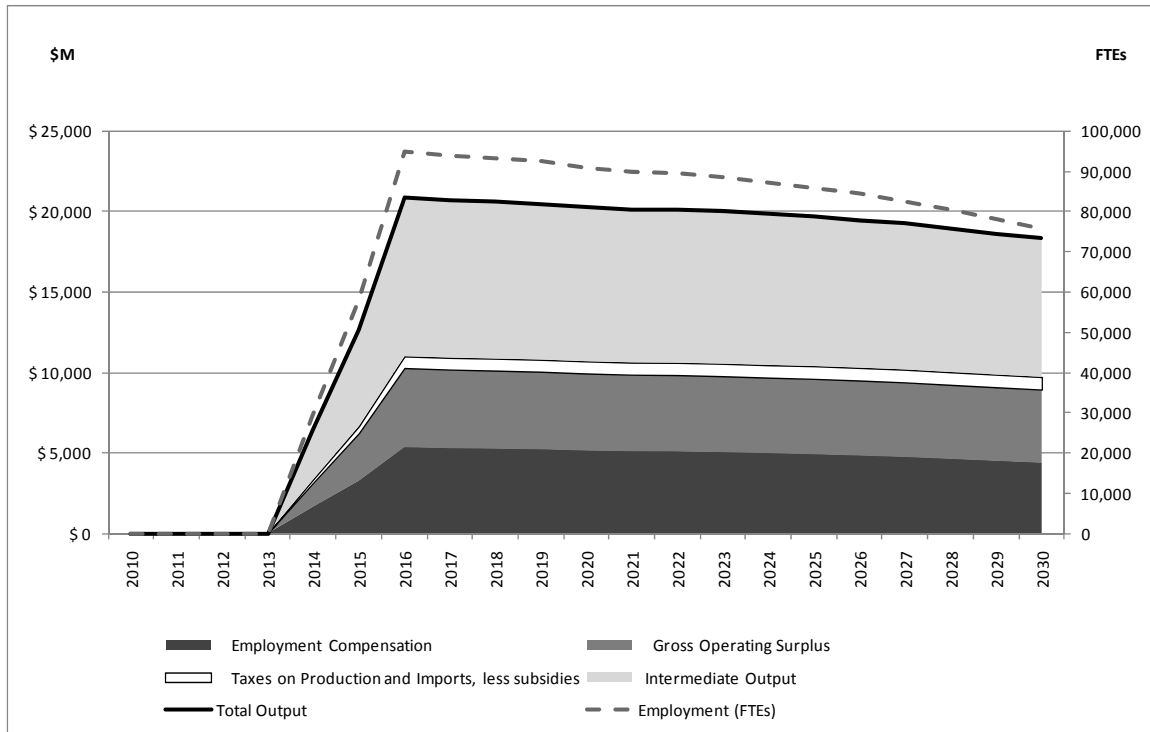

Figure 10: Import Substitution Output Impacts for Aggregate Sectors

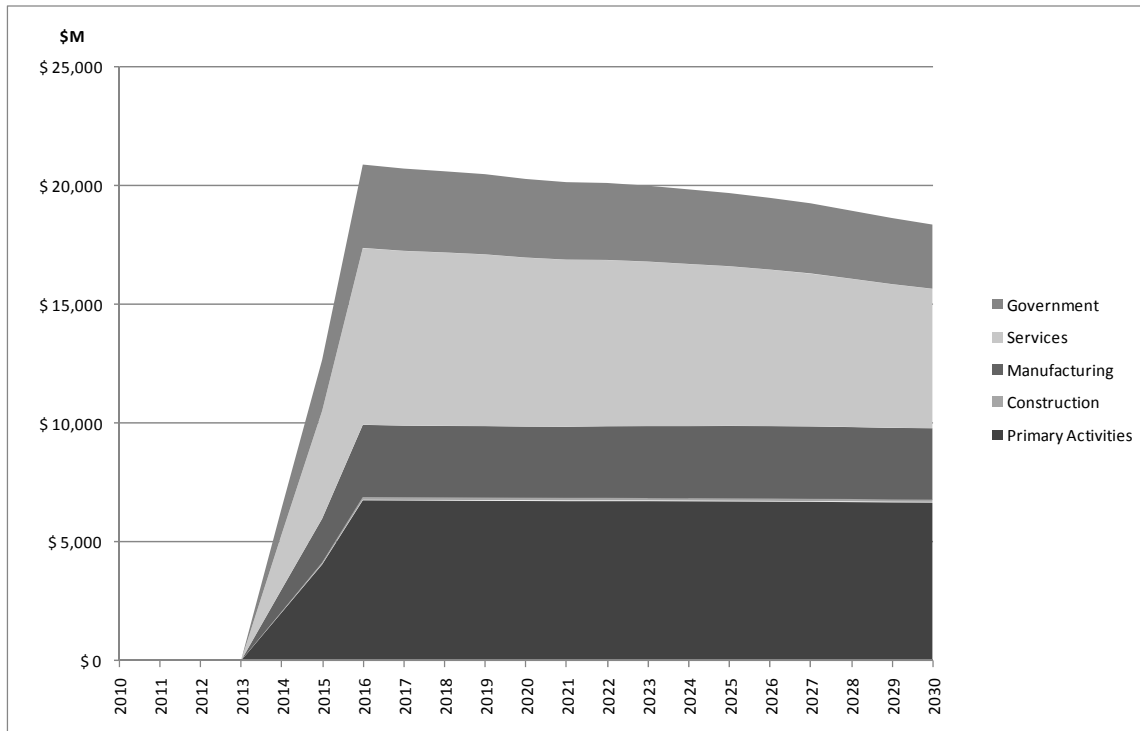

Figure 11: Import Substitution Employment Compensation Impacts for Aggregate Sectors

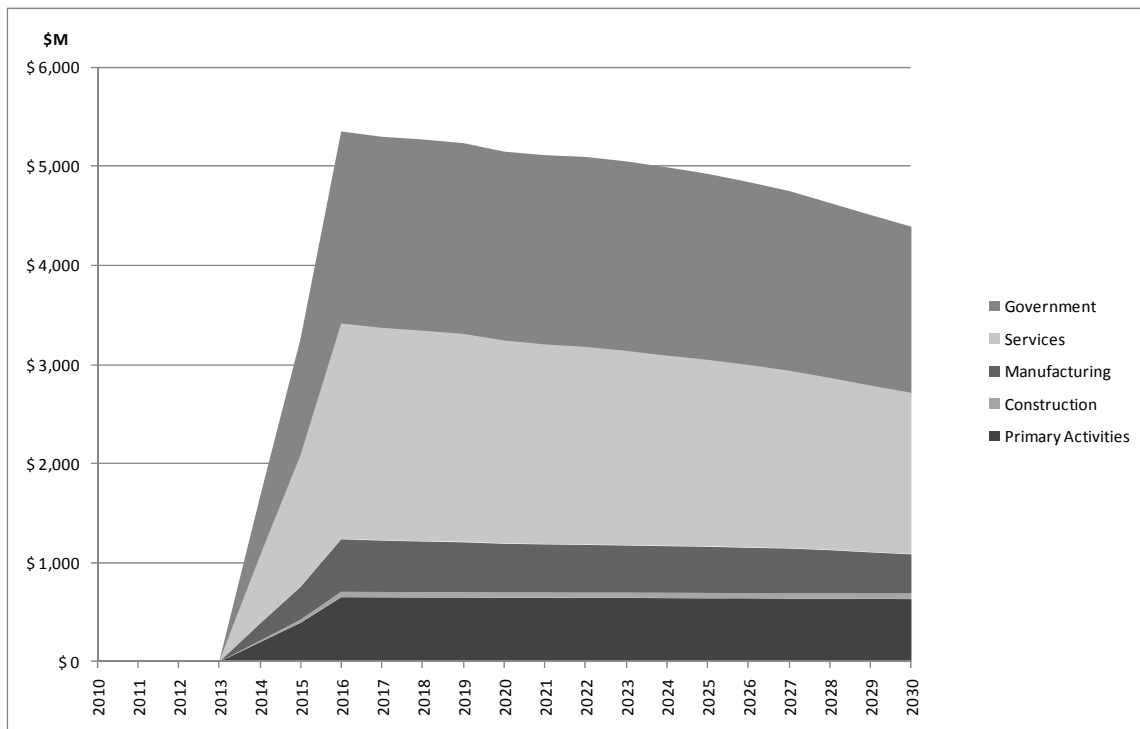

Figure 12: Import Substitution Employment Impacts for Aggregate Sectors

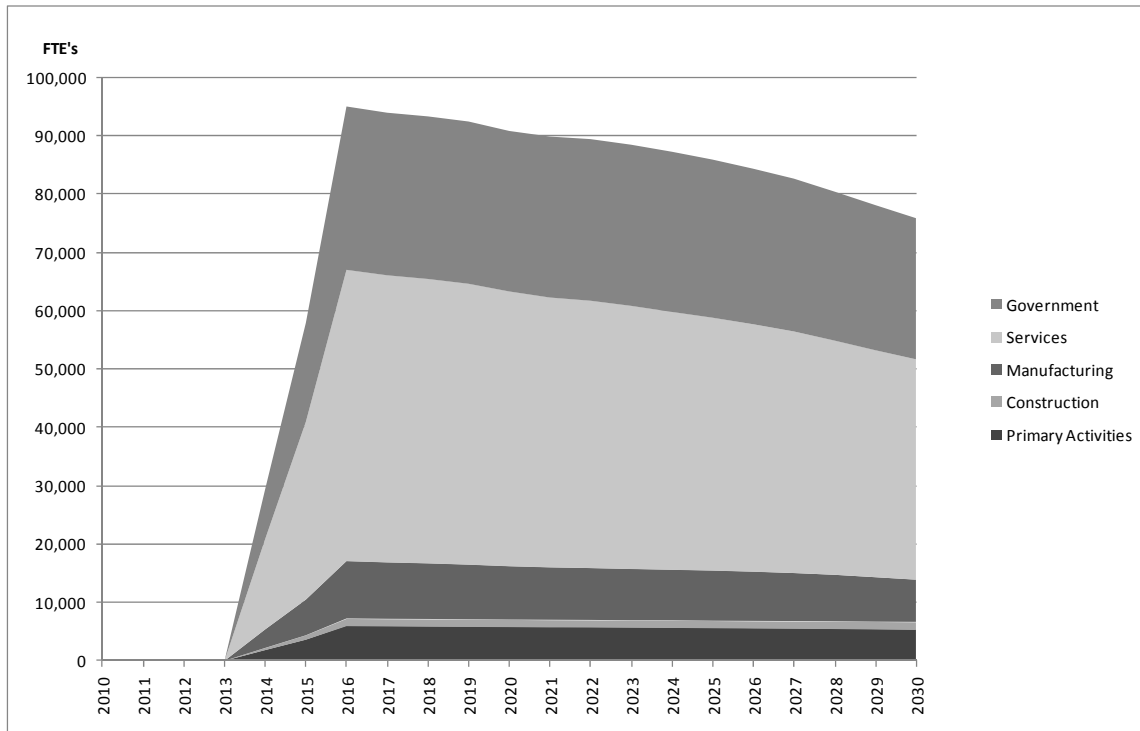

Figure 13: Total Output and Value Added Impacts from Construction

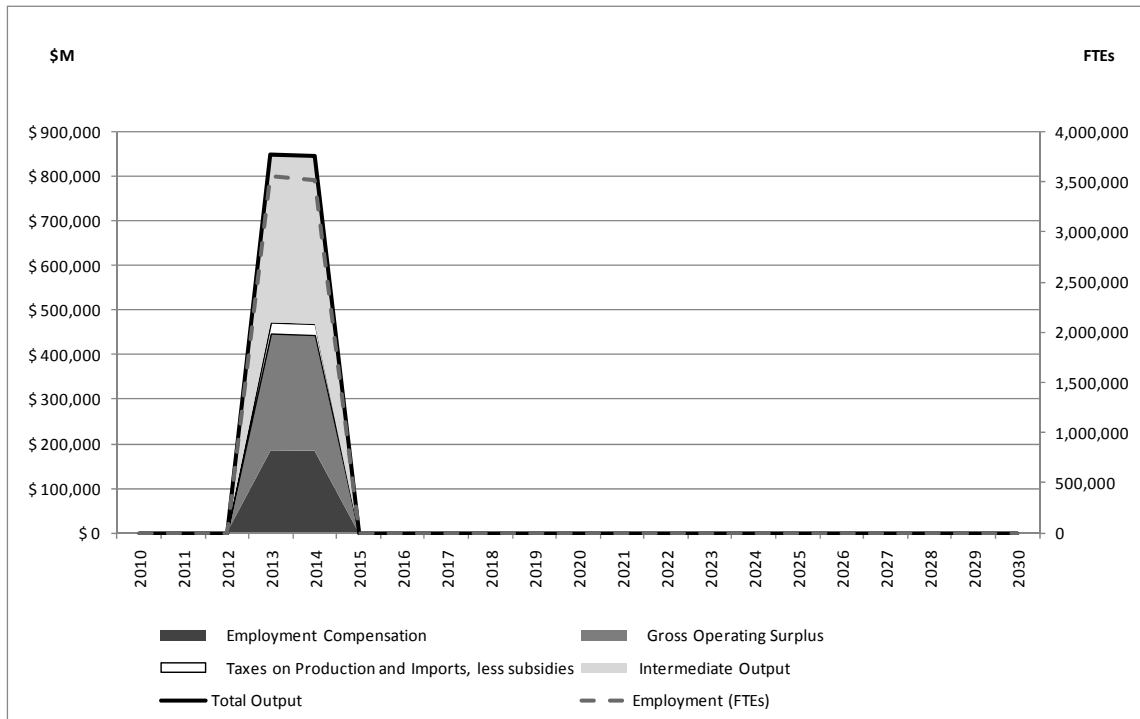

Figure 14: Construction Output Impacts for Aggregate Sectors

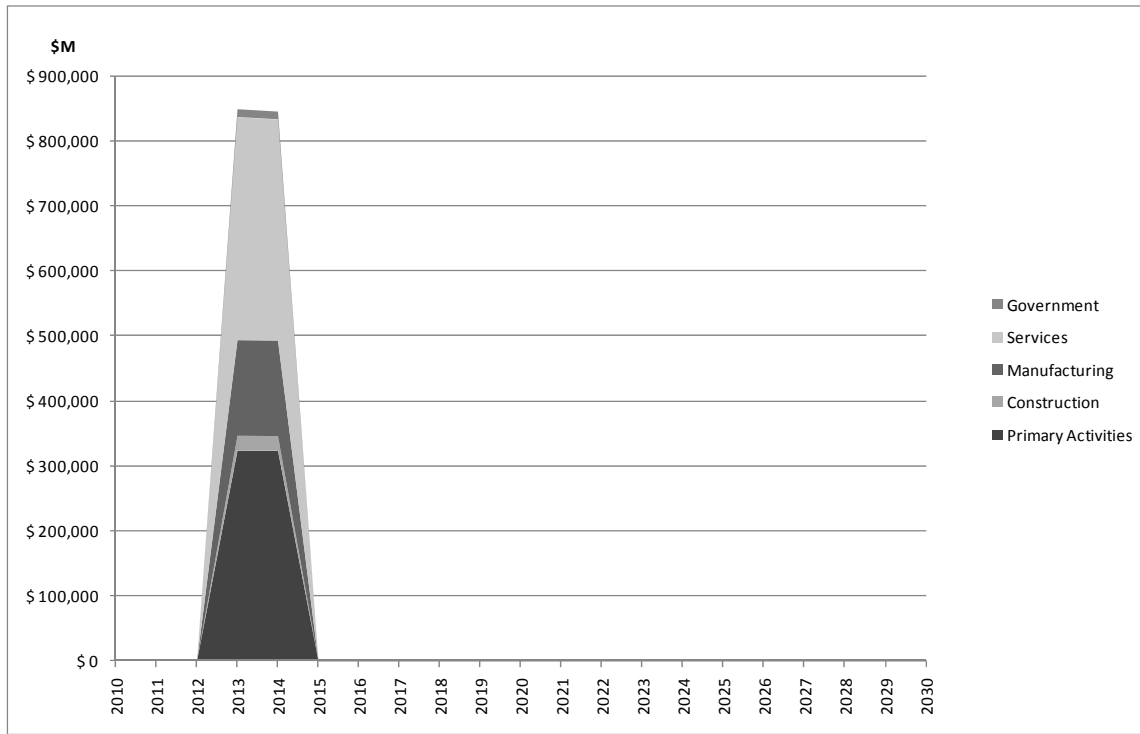

Figure 15: Construction Employment Compensation Impacts for Aggregate Sectors

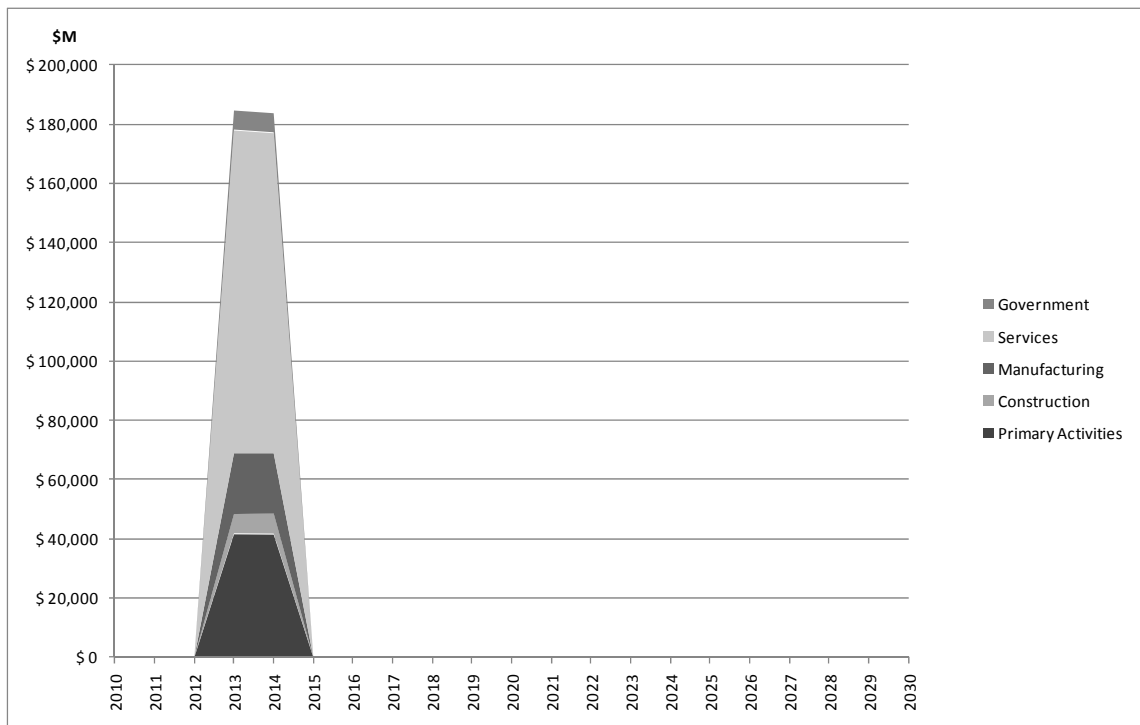
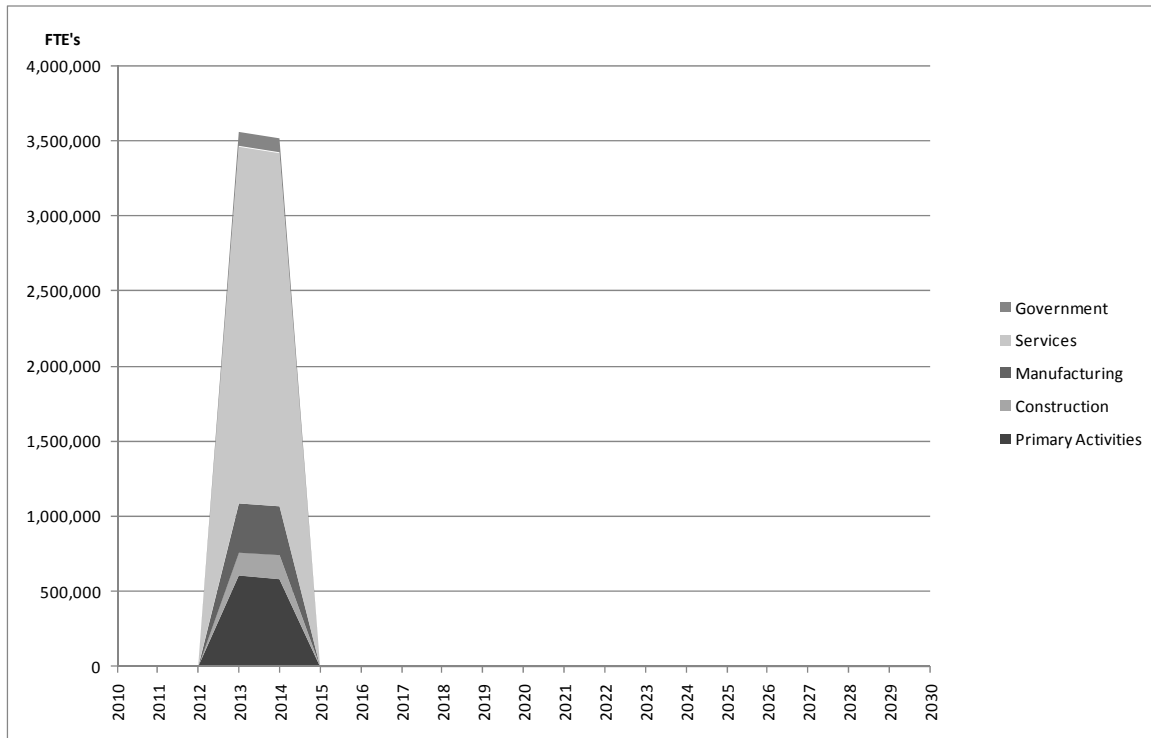

Figure 16: Construction Employment Impacts for Aggregate Sectors



## VI. Conclusions

This paper has demonstrated an approach to confronting conceptual issues that arise in the application of input-output analysis to the introduction of new technologies and the reweighting of subsector output composition over an extended time horizon. The application requires a great deal more time and effort than conventional input-output applications, but produces results that are consistent with the conceptual underpinnings of IO over the entire time horizon. The accuracy of results will depend on the accuracy of the forecast from which the data needed to re-scale economic structural representations for future years is obtained, but the advantage of this approach lies in its ability to fully incorporate future inter-industry structural representations, and its ability to explicitly capture the relationships among domestic production, imports, and domestic demand.

The model that results from this procedure lies along the continuum from input-output models to econometric models. Econometric models will normally provide detail on additional macro-level variables, and will capture some economic behaviors that are captured only implicitly and partially in this approach via the use of an econometric model for the generation of such variables as industry output levels, employment, employment compensation, household consumption, and imports. Typically, while econometric models will often have detail at the same industrial sector level, they do not incorporate detailed information on intermediate interindustry demand. Hybrid econometric-input-output models (Conway 1990; West 1991; Rey 1997; Rey and Dev 1997; Rey 1998; Rey and Jackson 1999; Rey 2000) are an alternative solution, but the trade-offs there lie in the need for additional time-series information, diminished flexibility in impact scenario specification, and more intensive model calibration efforts.

The modeling framework reported here can provide useful policy-relevant results. The results provide detailed industry-specific output requirements necessary to meet the changing intermediate and final demand structure. Although there are no supply constraints explicit in the method, the model can be used to generate activity levels that would be required to support the implementation of, for example, increased off-shore oil production, or the introduction and phasing in of CTL technology. The stress placed on current and forecast capacity can be identified by comparing the impact assessment activity levels to anticipated growth trends.

## Appendix A

### *Oil and Gas Price Ratio*

The oil and gas price ratio is necessary to adjust the composite price of oil and natural gas used in the model. The total consumption of oil and natural gas in the original setup is made up of both domestic oil and natural gas and internationally imported oil and natural gas. Domestic prices are not equal to the prices of the international imports. The composite price of oil and natural gas is therefore a weighted average of the region-specific domestic price and the price of international imports. When the model is run to estimate impacts, this composite price changes because the amount of domestic oil and natural gas being produced is now larger and imports have decreased. Therefore, the weights on the composite price will change. These changes should be reflected in an adjustment of the overall composite price of the *Oil and Natural Gas Extraction* commodity, and by subsequently modifying the corresponding Use table row using the ratio of new to old average price. This ratio is defined as follows:

$$p_k^{new} = \left[ \frac{p_i^k (Q_i^k + \Delta Q_i^k) + p_d^k (Q_d^k + \Delta Q_d^k)}{(Q_i^k + Q_d^k)} \right] \quad \text{and} \quad p_k^{old} = \left[ \frac{p_i^k Q_i^k + p_d^k Q_d^k}{(Q_i^k + Q_d^k)} \right]$$
$$f^k = \frac{p_k^{new}}{p_k^{old}} = \frac{p_i^k Q_i^k + p_d^k Q_d^k + p_i^k \Delta Q_i^k + p_d^k \Delta Q_d^k}{p_i^k Q_i^k + p_d^k Q_d^k} = 1 + \frac{p_i^k \Delta Q_i^k + p_d^k \Delta Q_d^k}{p_i^k Q_i^k + p_d^k Q_d^k}$$

where,

$k \in (\text{oil}, \text{gas})$

$p_i$  : import price

$p_d$  : domestic price

$Q_i$  : imported quantity

$Q_d$  : domestic quantity

$\Delta Q_i$  : change in imported quantity

$\Delta Q_d$  : change in domestic quantity

Within the aggregation scheme of this project, oil and natural gas extraction comprise a single industry, and are modeled as a composite commodity. Hence, the values for each component are weighted by the proportions of total value of the two commodities to determine the oil and gas price ratio.

$$\zeta = f^{composite} = \frac{f^{oil} p_{oil}^{new} Q_{oil}^{new} + f^{gas} p_{gas}^{new} Q_{gas}^{new}}{p_{oil}^{new} Q_{oil}^{new} + p_{gas}^{new} Q_{gas}^{new}}$$

where,

$$Q_{oil}^{new} = (Q_i^{oil} + \Delta Q_i^{oil}) + (Q_d^{oil} + \Delta Q_d^{oil})$$

$$Q_{gas}^{new} = (Q_i^{gas} + \Delta Q_i^{gas}) + (Q_d^{gas} + \Delta Q_d^{gas})$$

### Model Calculations

Base data that has been forecast and updated for user-interaction now undergoes the following model calculation steps in order to report impact results. The following is a step-by-step process for calculating results. This process occurs once for each impact year according to the user-specified impacts and phase-in schedules.

1. Domestic industry output,  $g$ , domestic commodity output,  $q$ , and total commodity output,  $q^t$ , are first calculated from the total Use matrix and the total Make matrix.

$$g = iU^t$$

$$q = iV$$

$$q^t = iV^t$$

where,  $i$  is a summing vector of the appropriate dimension (vector of all 1's) and

$$U^t = \begin{bmatrix} U \\ \hline GOS \\ \hline T \end{bmatrix}$$

$$V^t = \begin{bmatrix} V \\ \hline M \end{bmatrix}$$

2. Next, employment and value-added coefficients are calculated and stored as a matrix,  $W$ , to be used for results calculations. In the following calculations,  $./$ , indicates element-wise division.



|                          |                           |
|--------------------------|---------------------------|
| Employee Compensation:   | $\sigma^{EC} = EC. / g$   |
| Gross Operating Surplus: | $\sigma^{GOS} = GOS. / g$ |
| Taxes:                   | $\sigma^T = T. / g$       |
| Employment:              | $\sigma^e = e. / g$       |

$$W = \begin{bmatrix} \sigma^{EC} \\ \sigma^{GOS} \\ \sigma^T \\ \sigma^e \end{bmatrix}$$

3. The different specifications of the Make and Use tables (including the respective aggregate data for fossil fuels) are now standardized by their respective column sums.  $\hat{\cdot}$  indicates the diagonalized form of a vector.

Standardized Domestic Make:  $D = \left[ \begin{array}{c|c} V\hat{q}^{-1} & 0 \\ \hline 0 & 1 \end{array} \right]$

Standardized Total Make:  $D' = \left[ \begin{array}{c|c} V(\hat{q}')^{-1} & 0 \\ \hline 0 & 1 \end{array} \right]$

Standardized Use:  $B = U(\hat{g})^{-1}$

Standardized Domestic Impact Make:  $\tilde{D} = \left[ \begin{array}{c|c} \tilde{V}\hat{q}^{-1} & 0 \\ \hline 0 & 1 \end{array} \right]$

Standardized Impact Make:  $\tilde{D}' = \left[ \begin{array}{c|c} \tilde{V}(\hat{q}')^{-1} & 0 \\ \hline 0 & 1 \end{array} \right]$

Standardized Impact Use:  $\tilde{B} = \tilde{U}(\hat{g})^{-1}$

4. To determine output impacts, we must first calculate new industry output levels that correspond to the user-specified levels of fossil-fuel production. First, initial final demand levels are calculated.

$$Y^{IS} = [D(I - BD^t)^{-1}]^{-1} g$$

An additional data step ensures that the household final demand value does not change. We solve for the unique value of household output such that the calculated value for household final demand is equal to its known value.

$$g_{73}^H = \frac{\xi - \sum_{i=1}^{72} (g_i^H * IM_{73,i})}{IM_{73,73}}$$

where, 73 represents the household sector and  $IM$  is the initial multiplier matrix defined by:

$$IM = D(I - BD^t)^{-1}$$

Initial final demand is then updated to account for the user-defined international trade-feedback percentage. Once corrected for the international trade feedback percentage, the impact final demand vector is defined as:

$$\tilde{Y}^{IS} = \tilde{Y}^{IS} + X \left( \frac{\theta \mu}{\Sigma X} \right)$$

where,  $X$  is foreign exports by commodity,  $\theta$  is the value of displaced imports<sup>8</sup> and  $\mu$  is the user-defined international trade-feedback percentage.

This impact final demand vector is used to calculate new output values (millions of \$) after impacts have taken place.

$$g^{new} = \tilde{D}(I - \tilde{B}\tilde{D}^t)^{-1} \tilde{Y}^{IS}$$

An additional data step ensures that the increase in activity for the aggregate fossil-fuels industry is consistent with user-specifications. We solve for the unique value of final demand in the aggregate fossil-fuels industry such that the calculated value for aggregate fossil-fuels industry activity is equal to its known value.

---

<sup>8</sup>  $\theta = Reduction\_IntlImportPayments\_O + Reduction\_IntlImportPayments\_G + Reduction\_IntlImportPetRef\_C + Reduction\_IntlImportOtherPet\_C + Reduction\_IntlImportOtherChem\_C$

$$\tilde{Y}_3^{IS} = \frac{\tilde{g}_3 - \left[ \sum_{i=1}^2 (\tilde{g}_i * PM_{3,i}) + \sum_{i=4}^{73} (\tilde{g}_i * PM_{3,i}) \right]}{PM_{3,3}}$$

where, 3 represents the aggregate fossil-fuels sector,

$$\tilde{g}_3 = g_3 + \text{ExtractionIndustryOutput}_G + \text{ExtractionIndustryOutput}_O + \text{Increase\_DieselVal}_C \\ + \text{Increase\_NaphthaVal}_C$$

and  $PM$  is the impact multiplier matrix defined by:

$$PM = \tilde{D}(I - \tilde{B}\tilde{D}^t)^{-1}$$

The aggregate new output value for Sector 3 is then disaggregated into output impacts for Onshore Oil and Gas Extraction, Offshore Oil and Gas Extraction, and CTL. Since the values for new Offshore Oil and Gas Extraction and CTL output are defined by user-entries, we can assign these values and calculate new output for Onshore Oil and Gas Extraction as:

$$g_{3,On}^{new} = \tilde{g}_3 - \text{ExtractionIndustryOutput}_G_{Off} - \text{ExtractionIndustryOutput}_O_{Off} - \\ \text{Increase\_DieselVal}_C - \text{Increase\_NaphthaVal}_C$$

In cases for which onshore impacts differ from those specified by a user input, differences reflect the indirect adjustments in intermediate and final demand.

5. This disaggregated new output vector is then used to calculate output impacts,  $P^g$  and corresponding results tables.

$$P^g = g^{new} - g$$

For results presentation, total output impacts are broken down in terms of their respective value-added components and employment impacts are calculated using  $W$ .

$$VA^{IS} = W(\hat{P}^g)$$

6. Construction impacts are determined by defining a construction final demand vector,  $Y^C$ . This vector is populated using the respective construction values from fossil-fuels calculation steps. It is then used to calculate construction output impacts.

$$C^g = D(I - BD^t)^{-1}Y^C$$

These impacts are also broken down in terms of their value-added components and respective employment impacts.

$$VA^C = W(\hat{C}^g)$$

## References

- Chenery, H. B., S. Shishido, and T. Watanabe. 1962. The pattern of Japanese Growth, 1914-1954. *Econometrica* 30 (January):98-139.
- Conway, R. S. J. 1990. The Washington Projection and Simulation-Model - a Regional Interindustry Econometric-Model. *International regional science review* 13 (1-2):141-165.
- Energy Information Administration. 2009. Model Documentation: National Energy Modeling System. Washington, D.C. [http://tonto.eia.doe.gov/reports/reports\\_kindD.asp?type=model documentation](http://tonto.eia.doe.gov/reports/reports_kindD.asp?type=model%20documentation)
- Feldman, Stanley J., David McClain, and Karen Palmer. 1987. Sources of Structural Change in the United States, 1963-78: An Input-Output Perspective. *The Review of Economics and Statistics* 69(3): 503-510.
- Jackson, R. W. 1989. Probabilistic input output analysis - modeling directions. *Socio-economic planning sciences* 23 (1-2):87-95.
- Lahr, M. L., and B. H. Stevens. 2002. A study of the role of regionalization in the generation of aggregation error in regional input-output models. *Journal of regional science* 42 (3):477-507.
- Miller, R. E., and P. D. Blair. 1985. *Input-Output Analysis: Foundations and Extensions*. Englewood Cliffs, New Jersey: Prentice-Hall.
- eds. 2009. *Input-Output Analysis: Foundations and Extensions*. 2 ed. Cambridge, UK: Cambridge University Press.
- Morimoto, Y. 1970. On aggregation problems in input-output analysis. *Review of Economic Studies* 1:119-126.
- Rey, S. J. 1997. Integrating regional econometric and input-output models: An evaluation of embedding strategies. *Environment & planning a* 29 (6):1057-1072.
- . 1998. The performance of alternative integration strategies for combining regional econometric and input-output models. *International regional science review* 21 (1):1-35.
- . 2000. Integrated regional econometric+input-output modeling: issues and opportunities. *Papers in Regional Science* 79 (4):271.
- Rey, S. J., and B. Dev. 1997. Integrating econometric and input-output models in a multiregional context. *Growth and change* 28 (2):222-243.
- Rey, S. J., and R. W. Jackson. 1999. Labor-productivity changes in regional econometric plus input-output models. *Environment & planning a* 31 (9):1583-1599.
- Romanoff, E., and S. H. Levine. 1981. Anticipatory and responsive sequential inter-industry models. *Ieee Transactions on Systems Man and Cybernetics* 11 (3):181-186.
- . 1986. Capacity limitations, inventory, and time-phased production in the sequential interindustry model. *Papers of the Regional Science Association* 59:73-91.
- Stevens, B. H., and M. L. Lahr. 1993. *Sectoral aggregation error in regional input-output models: a simulation study*. [Peace Dale, R.I.]: Regional Science Research Institute.
- West, G. R. 1991. A Queensland input-output econometric model: An Overview. *Australian Economic Papers* 30 (57):221-240.